

R-25

Unit:mm

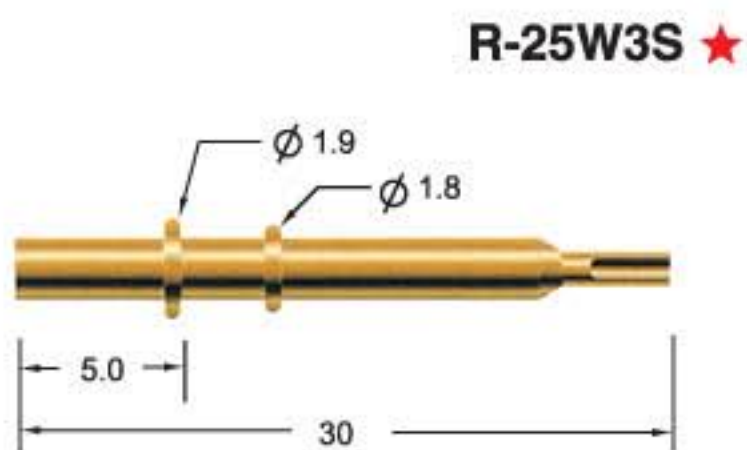
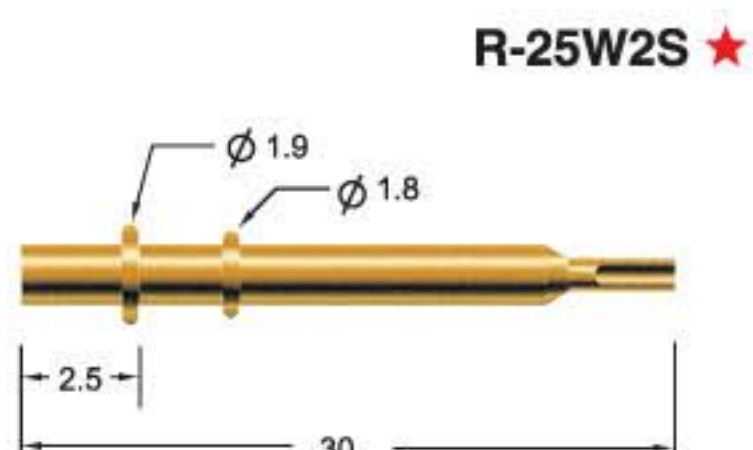
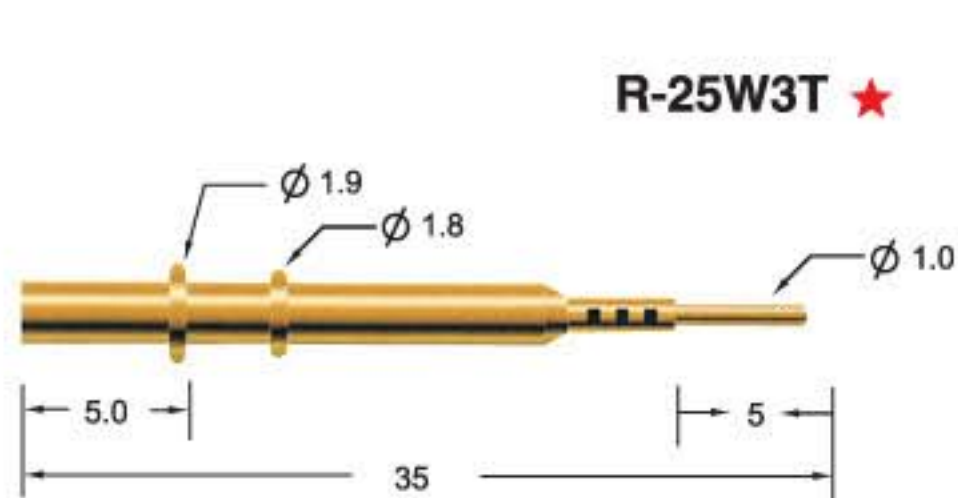
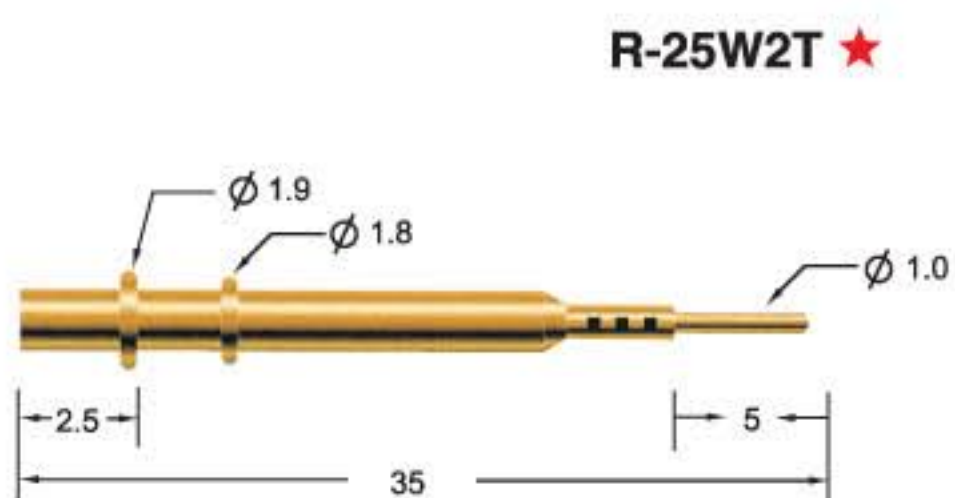
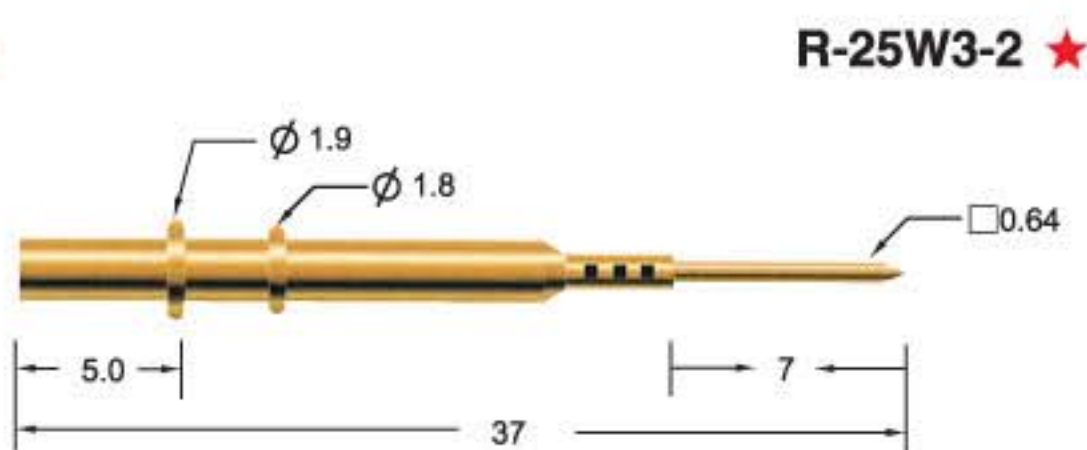
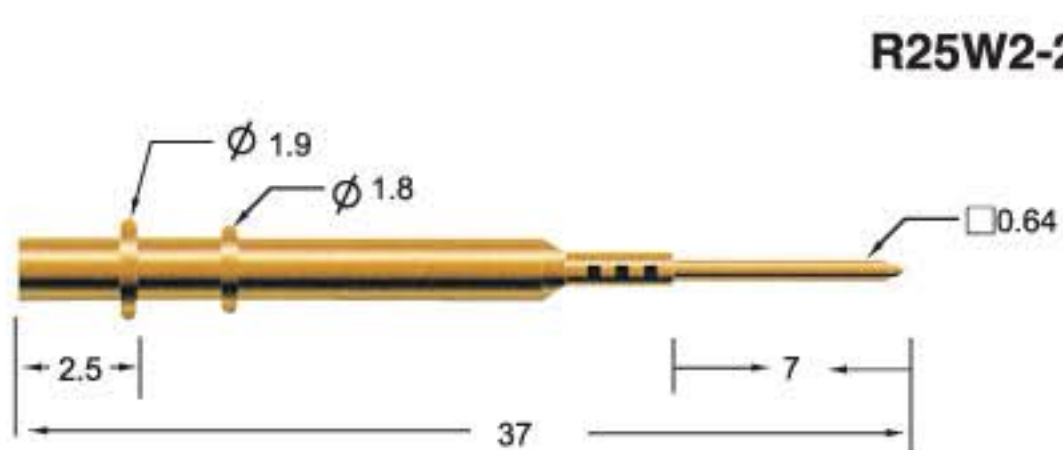
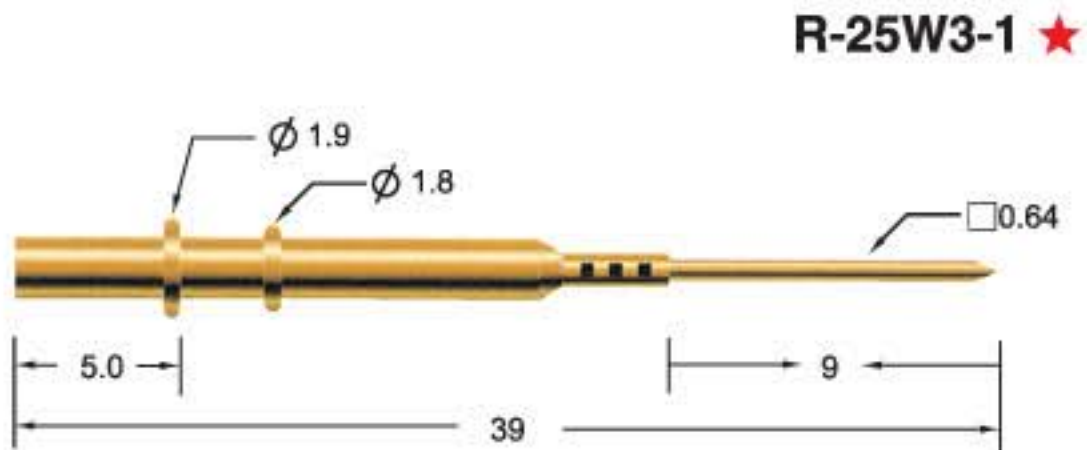
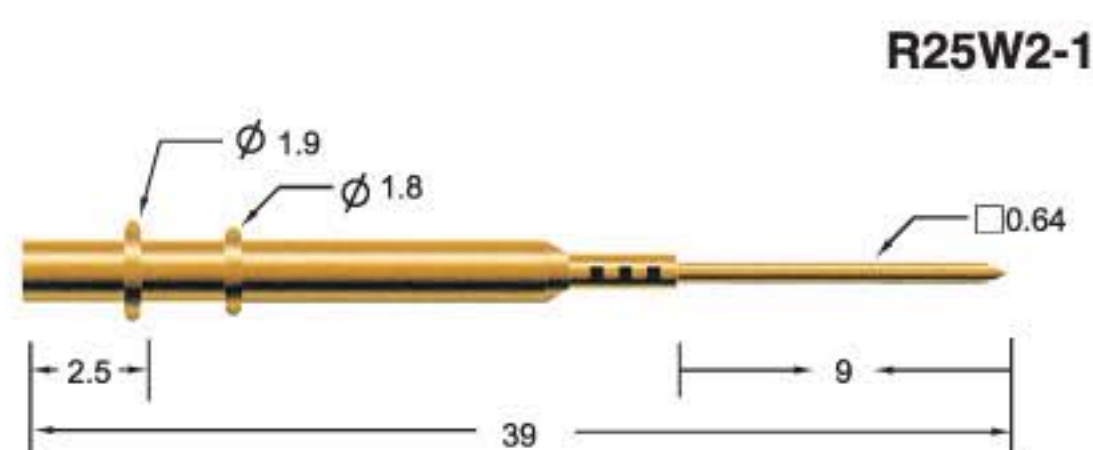
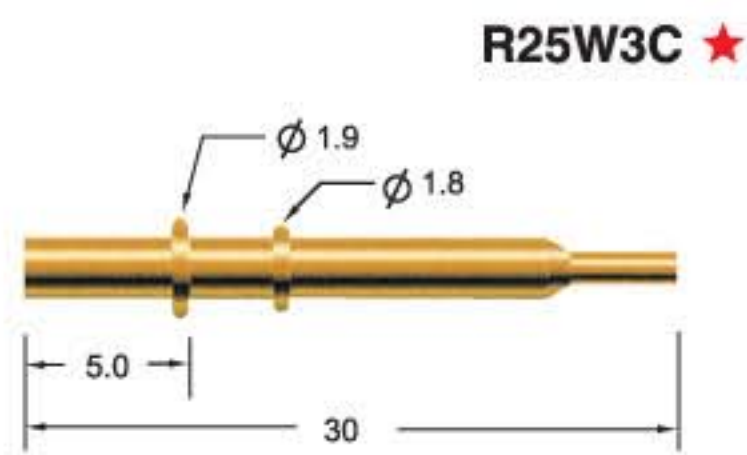
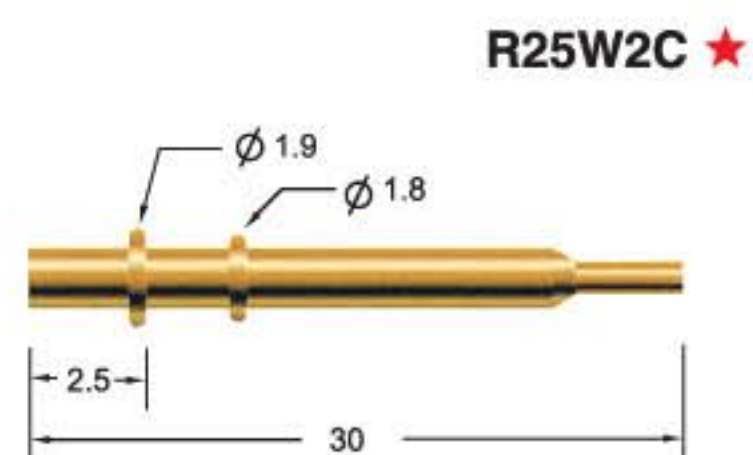

Probe specifications R-25

- Recommended min. center (最小間距) : 2.54 (0.1")
- Mounting hole size (鑽孔尺寸) : 1.7 (.0669") / 1.75 (.0689")
- Materials and finishes (材料及塗飾) : Brass, Gold plated
- Connections (接線形式) :
 Crimp: R-25W2C, R-25W3C, R-25W4C, R-25W5C
 Solder cup: R-25W2S, R-25W3S, R-25W4S
 Wire wrap: R-25W2-1, R-25W2-2
 R-25W3-1, R-25W3-2, R-25W4-1, R-25W4-2
 R-25W5-2
 Twrminal: R-25W2T, R-25W3T, R-25W4T, R-25W5T
- ★ 為訂製品代號