

R-11

Unit:mm

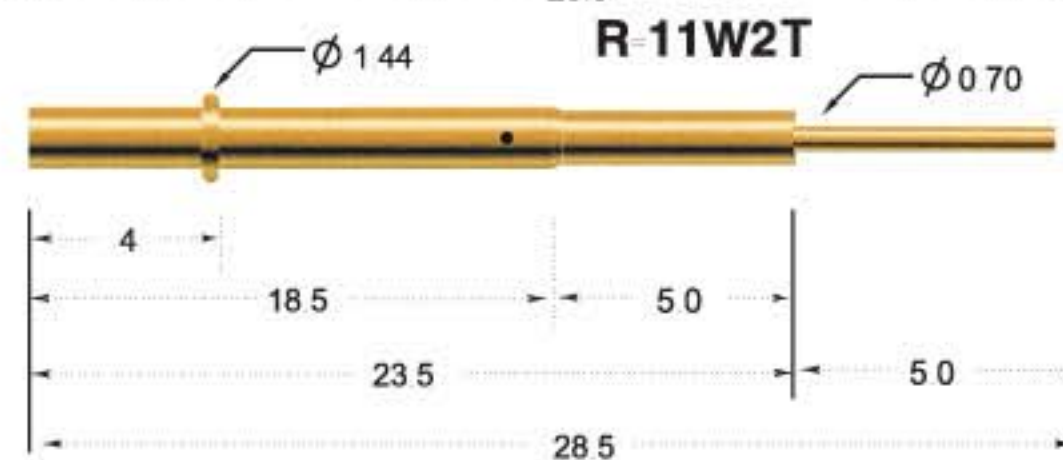
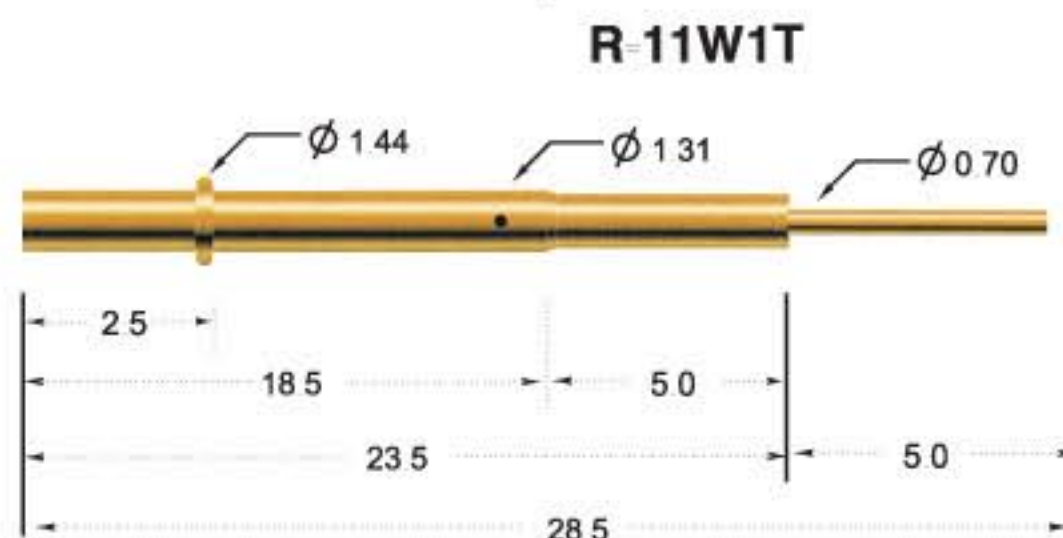
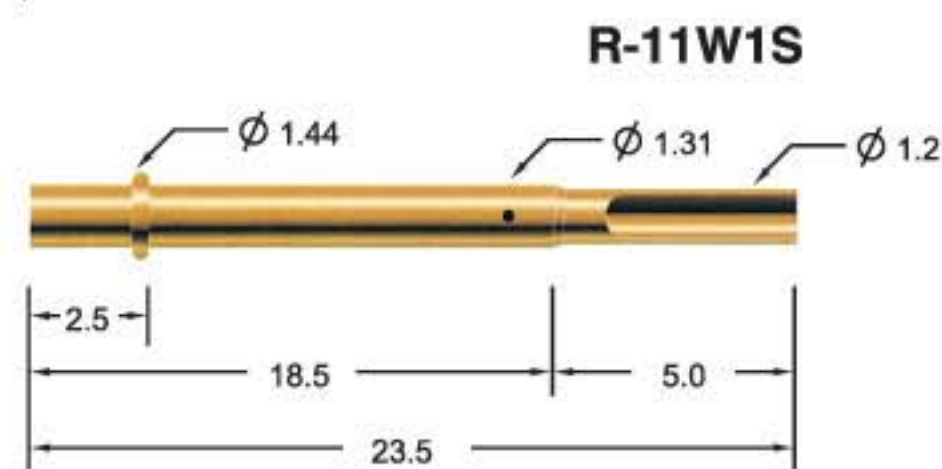
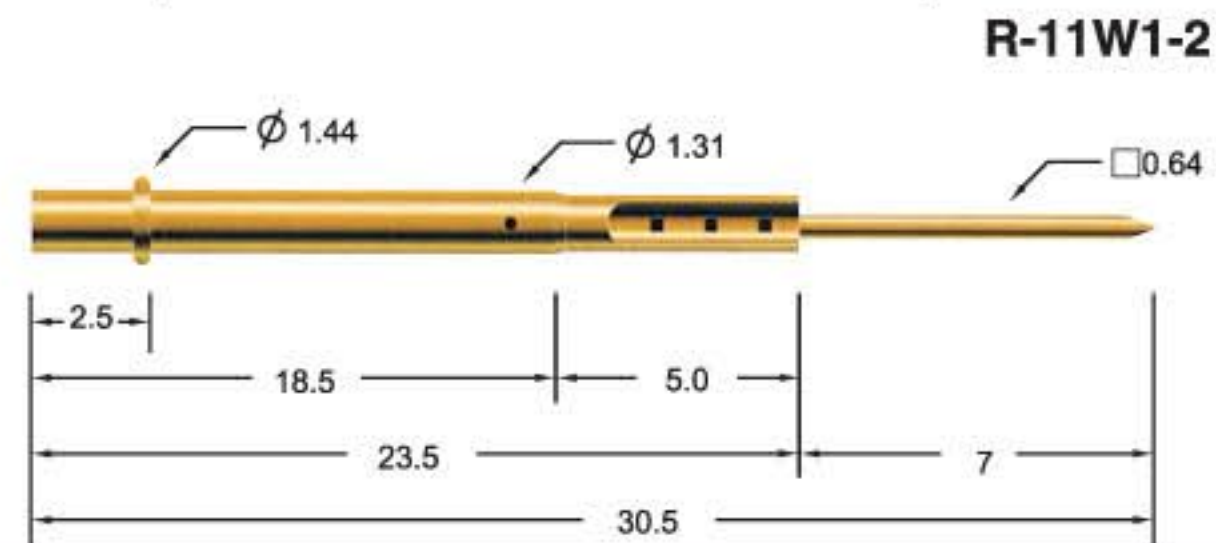
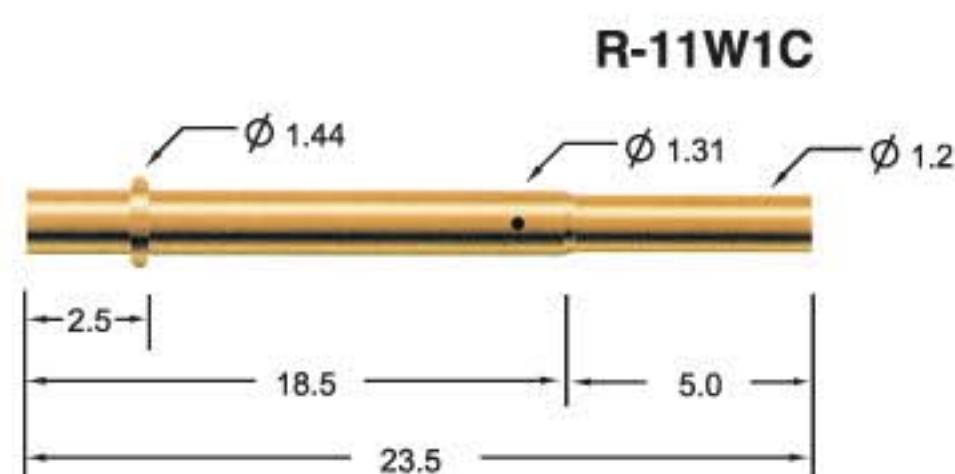
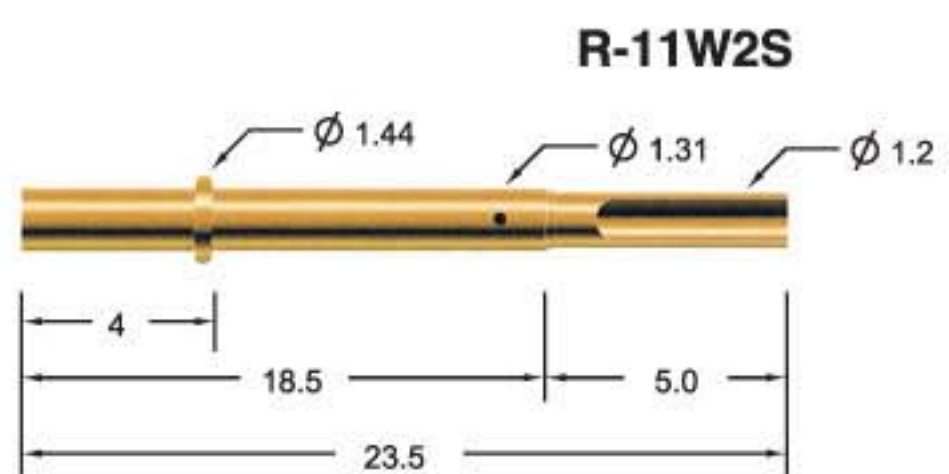
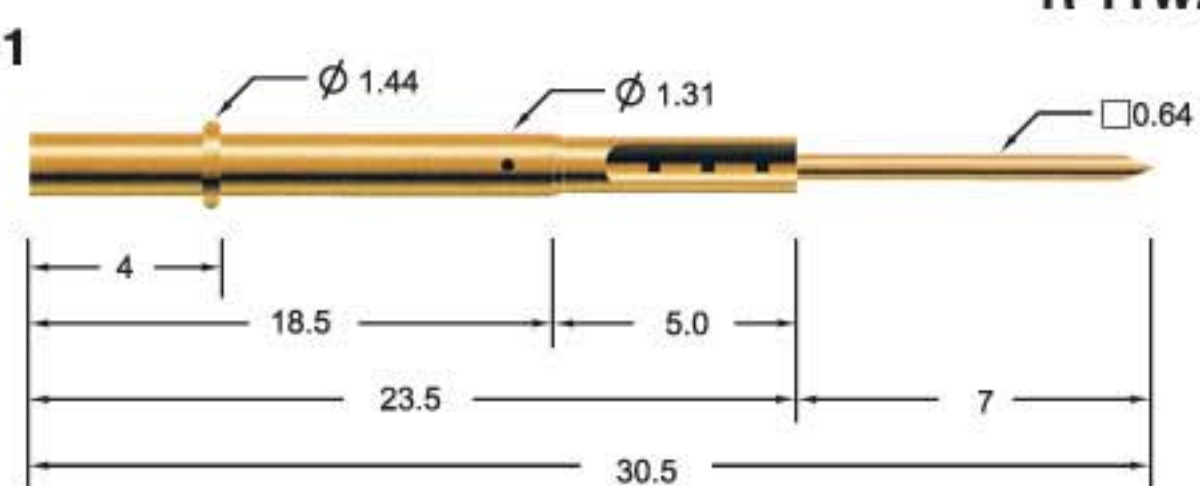
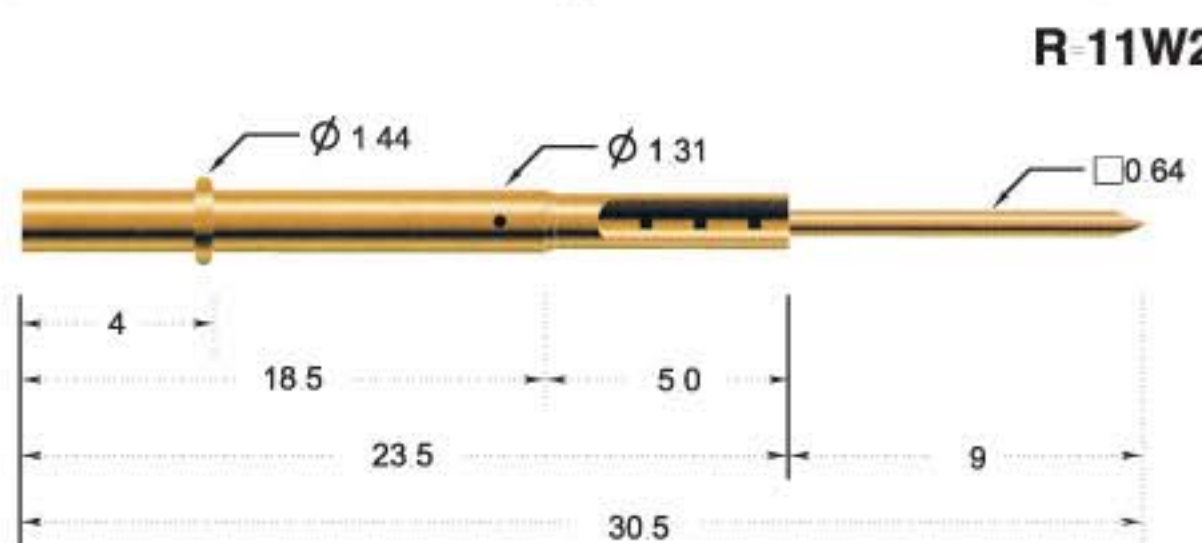
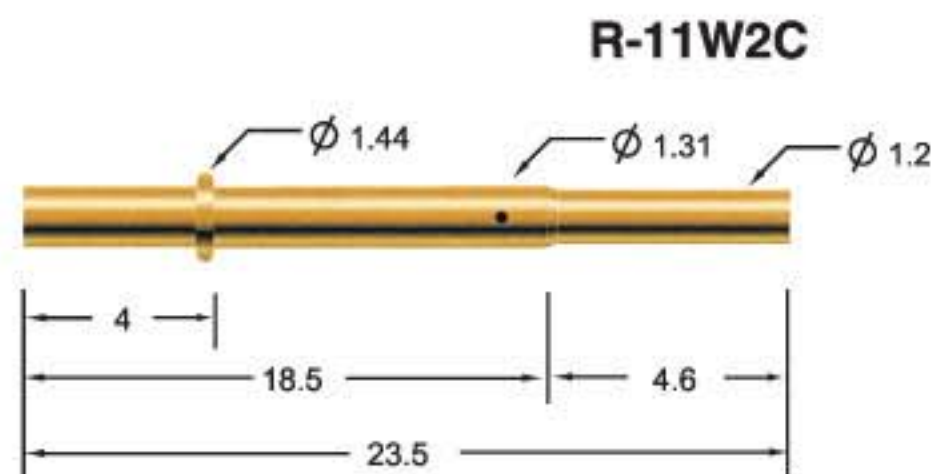
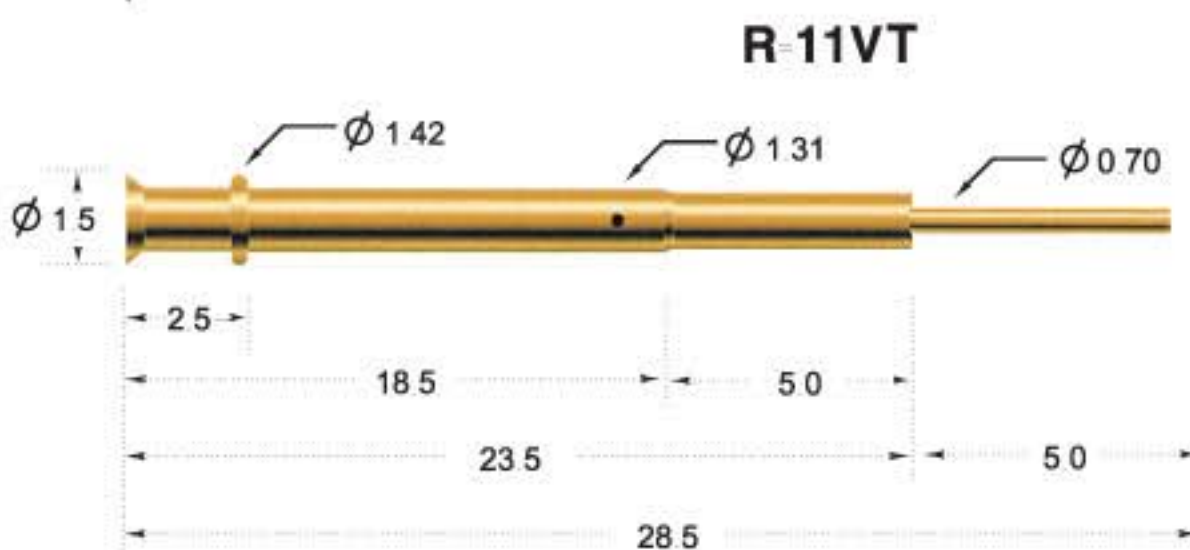
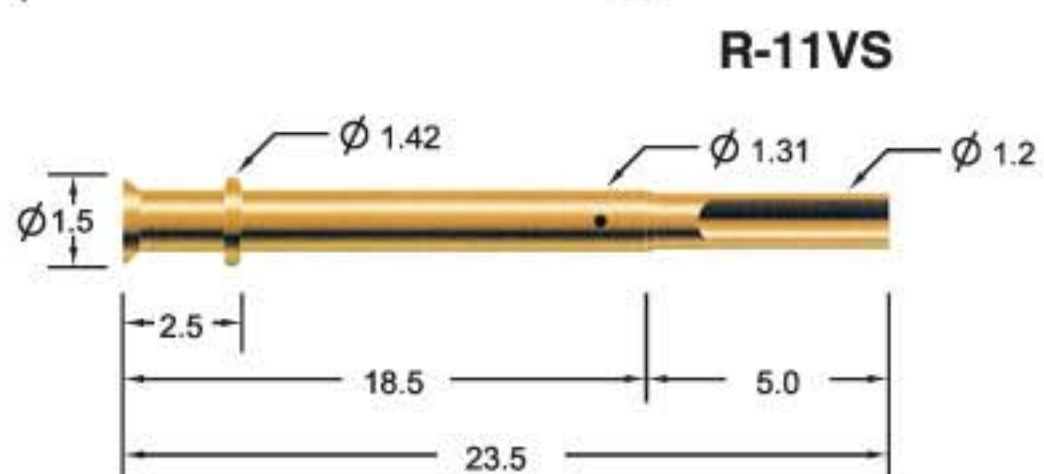
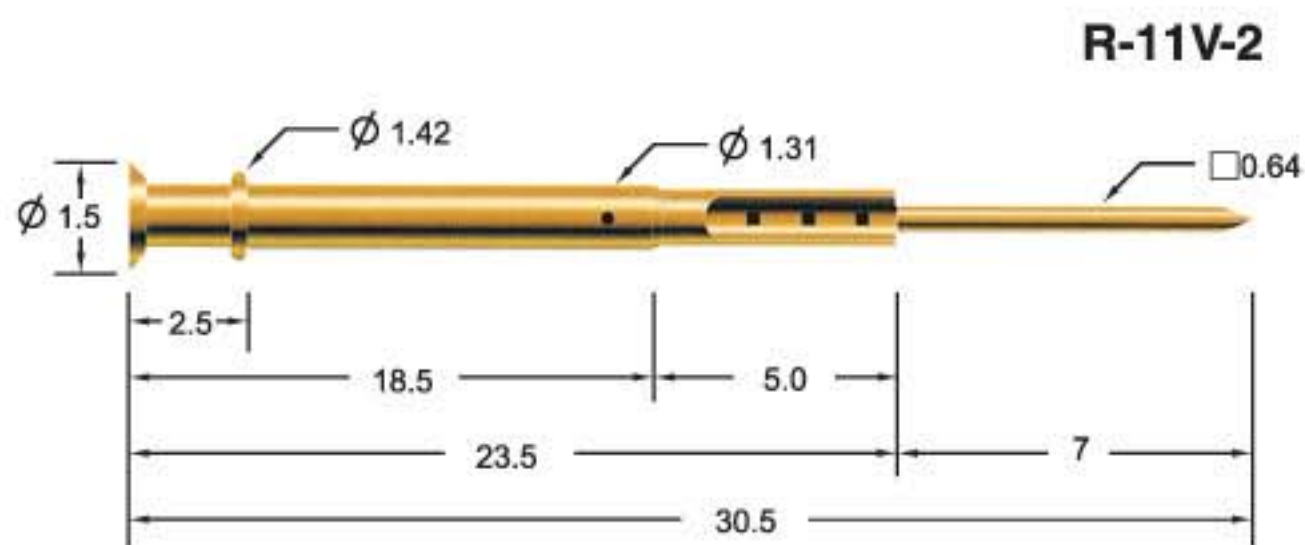
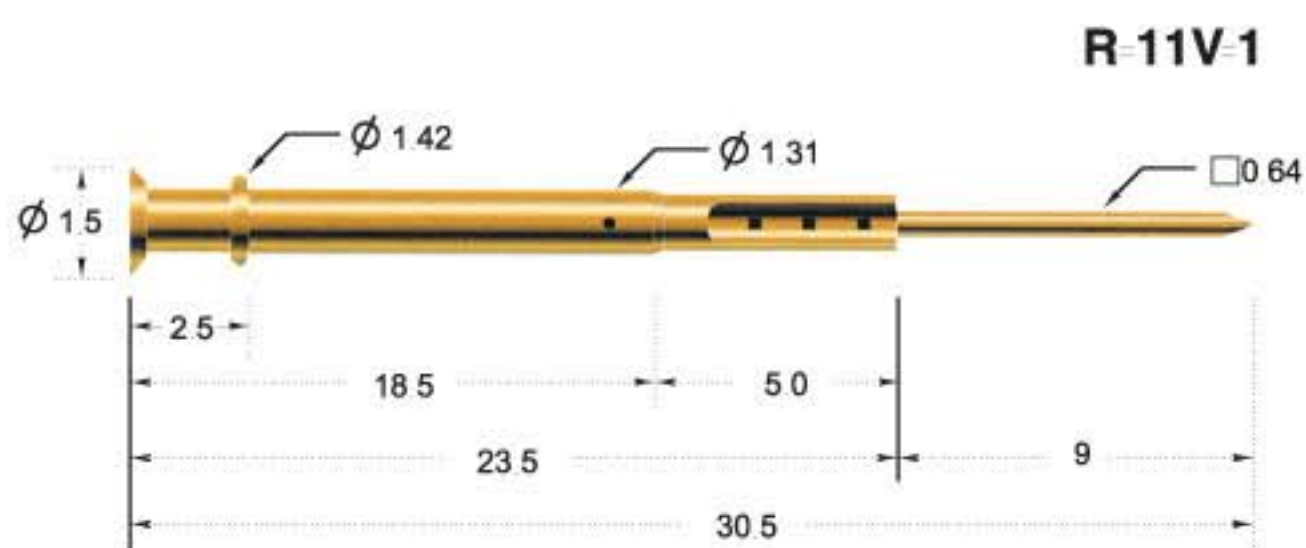
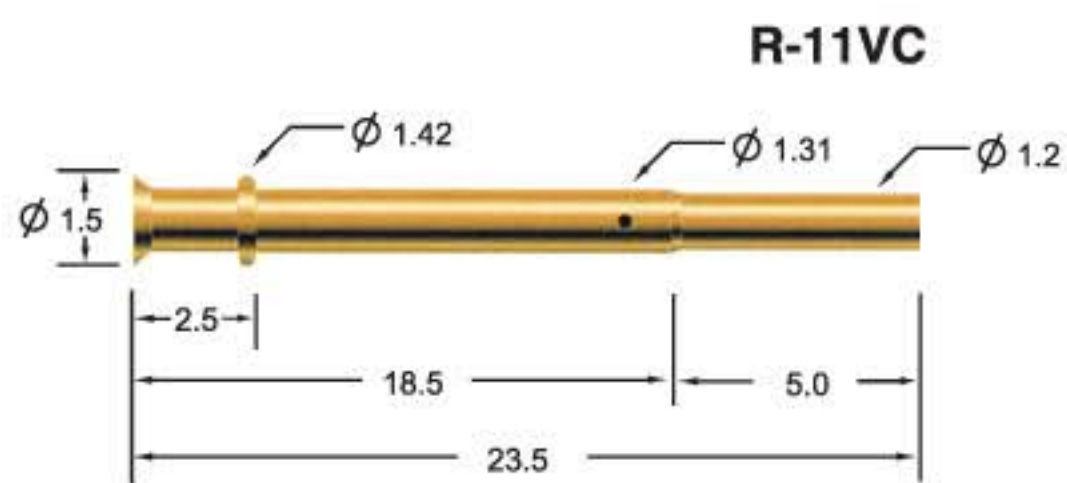

Probe specifications R-11

- Recommended min. center (最小間距) : 1.9 (.0748")
- Mounting hole size (鑽孔尺寸) : 1.35 (.0531") / 1.4 (.0551")
- Materials and finishes (材料及塗飾) : Brass, Gold plated
- Connections (接線形式) :
 - Crimp: R-11VC, R-11W1C, R-11W2C
 - Solder cup: R-11VS, R-11W1S, R-11W2S
 - Wire wrap: R-11V-2, R-11W1-2, R-11W2-2